



LED INDUSTRIAL EMERGENCY LIGHT | 6 VOLT | ADJUSTABLE HEAD LAMPS

Code: EL-HDLED



All new LED Heavy Duty Emergency light with remote head capable option. Includes maintenance free battery backup, works on either 120V or 277V. Remote capacity up to 20W.



FEATURES

- UL 924, NEC, OSHA and NFPA 101 Life Safety Code
- UL Listed for Damp Locations
- Universal 120/277 VAC (60Hz) input
- Includes two adjustable LED 1.5W lamp heads
- Remote Capacity of 20W in Standard
- Automatic low voltage disconnect (LVD)
- Push-to-test switch
- Charge rate / power-on indicator light

WARRANTY INFORMATION

Any component that fails due to manufacturer's defect is guaranteed for 1 year. The warranty only covers products installed and maintained in accordance with the instructions provided by their respective manufacturer and no warranty is made with respect to any of our products that are otherwise installed or maintained. For full warranty details, visit our Warranty Section.

Conformance to Codes and Standards

The EL-HD12 Emergency Light is UL listed and meets or exceeds the following: UL 924, NEC, OSHA and NFPA 101 Life Safety Code requirements.

ORDERING INFORMATION

Series	Housing Color	Operation Type
EL-HDLED	W (White)	BB (Battery Backup)
	B (Black)	

CONSTRUCTION

The EL-HDLED Heavy Duty Emergency Light is constructed from 20-gauge steel with a white or black finish. Head lamps are constructed from injection-molded engineering grade high-impact thermoplastic.

ILLUMINATION

The EL-HDLED Heavy Duty Emergency Light comes with 2 fully adjustable LED head lamps. Each lamp is equipped with 12 x .125W LEDs.

ELECTRICAL COMPONENTS

Dual voltage input 120/277 VAC operation. LED display indicates AC/ON. An external push button test switch allows maintenance personnel to quickly determine the operational status of the unit. Unit offers surge protected, solid state circuitry.

EMERGENCY OPERATION

Upon failure of the normal utility power, an internal solidstate transfer switch automatically provides uninterrupted emergency operation for at least 90 minutes. The fully automatic solid-state, two-rate charger initiates battery charging to recharge a discharged battery in 24 hours.

BATTERY - BATTERY BACKUP

The EL-HDLED Emergency Light comes with maintenance-free 6V 12Ah rechargeable sealed lead acid batteries.

OPERATIONAL TEMPERATURE

Temperature Ratings

Series	Temperature
Battery Backup	20°C to 50°C / 68°F to 122°F

REMOTE HEAD CAPABLE OPTION

The total capacity is 27W for the entire unit (20W remote capacity). This allows the EL-HDLED unit to supply power to additional 6V remote heads. These remote heads would then operate on the same emergency mode as the standard units (see Emergency Operation Section).

INSTALLATION

The EL-HDLED Heavy Duty Emergency Light is suitable for wall installation via included mounting plate. Includes side and top knockouts for conduit feed applications.

DIMENSIONS

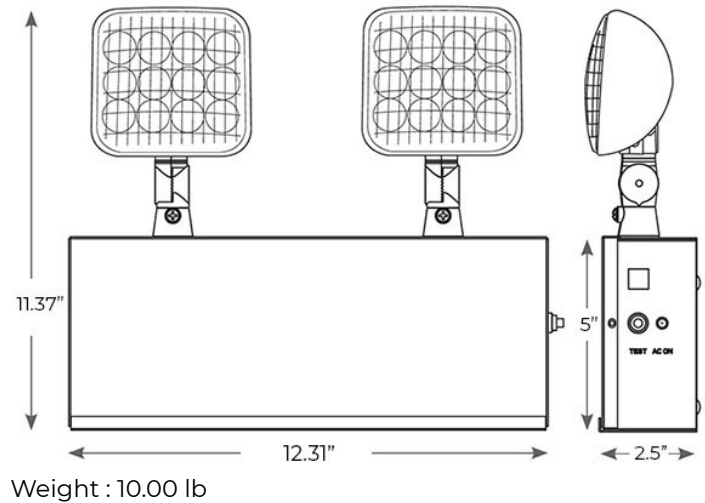

3170 Scott St, Vista, CA 92081
Phone: 877-352-3948 | Fax: 877-352-3949
info@exitlightco.com