

LED WEATHERPROOF EMERGENCY LIGHT

Code: EL-LWET



The EL-LWET Heavy Duty LED Emergency Light is not only ideal for wet locations, its durable design is also resistant to corrosive atmospheres and harsh environments.



Compatible Remote Head(s): RHB-WPL

FEATURES

- UL 924, CSA Listed, and Wet Location Listed
- Fully sealed and gasketed housing
- Includes two 15 LED lamp heads
- Maintenance-free sealed battery
- Sealed momentary push-to-test switch & AC indicator light

WARRANTY INFORMATION

Any component that fails due to manufacturer's defect is guaranteed for 1 year. The warranty only covers products installed and maintained in accordance with the instructions provided by their respective manufacturer and no warranty is made with respect to any of our products that are otherwise installed or maintained. For full warranty details, visit our Warranty Section.

Conformance to Codes and Standards

The EL-LWETLED is UL listed and meets or exceeds the following: UL 924 and CSA.

ORDERING INFORMATION

Series	Operation Type
EL-LWET	BB (Battery Backup)
	RH (Remote Head Capable)

CONSTRUCTION

The EL-LWET Emergency Light is constructed from corrosion resistant and impact resistant thermoplastic housing. Resistant to corrosive atmosphere, harsh environments and non-hazardous dust environments. UL listed for wet location and designed to withstand hose-downs, water spray and splashing water.

ILLUMINATION

EL-LWET emergency unit uses two top mounted heads lamps (15 LEDs in each lamp). Heads are constructed from high impact thermoplastic. Fully-adjustable.

ELECTRICAL COMPONENTS

Dual voltage input 120/277 VAC operation. LED display indicates AC/ON. An external push button test switch allows maintenance personnel to quickly determine the operational status of the unit.

EMERGENCY OPERATION

Upon failure of the normal utility power, an internal solidstate transfer switch automatically provides uninterrupted emergency operation for at least 90 minutes. The fully automatic solid-state, two-rate charger initiates battery charging to recharge a discharged battery in 24 hours.

BATTERY - BATTERY BACKUP

The EL-LWET Emergency Light is designed with a maintenance-free 9.6V NiCad battery that provides a minimum emergency duration of 90 minutes. Recharge time of the battery is 24 hours.

OPERATIONAL TEMPERATURE

Temperature Ratings

Series	Temperature
Standard Option	10°C to 40°C / 50°F to 104°F

REMOTE HEAD CAPABLE OPTION

The remote head capability option allows the EL-LWET unit to supply power to up to two additional 9.6V remote heads. The remote heads would then operate on the same emergency mode as the standard units (see Emergency Operation Section).

INSTALLATION

The EL-LWET is suitable for surface wall mounting. Optional hardware is included. Hinged front access panel allows for trouble free installation and maintenance.

DIMENSIONS

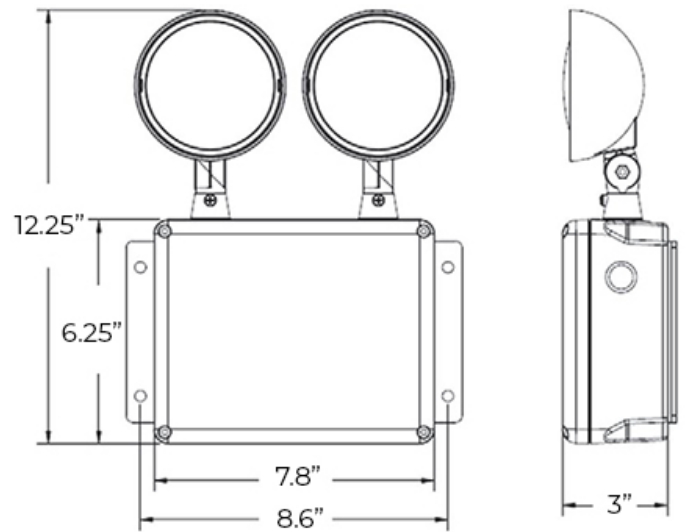

Weight : 10.00 lb

3170 Scott St, Vista, CA 92081
Phone: 877-352-3948 | Fax: 877-352-3949
info@exitlightco.com